

Received
Planning Division
11/03/2023



Building 1 (Lots 156-158)

3/16" = 1'-0"

ENTRY ELEVATION

CONTEMPORARY FRENCH

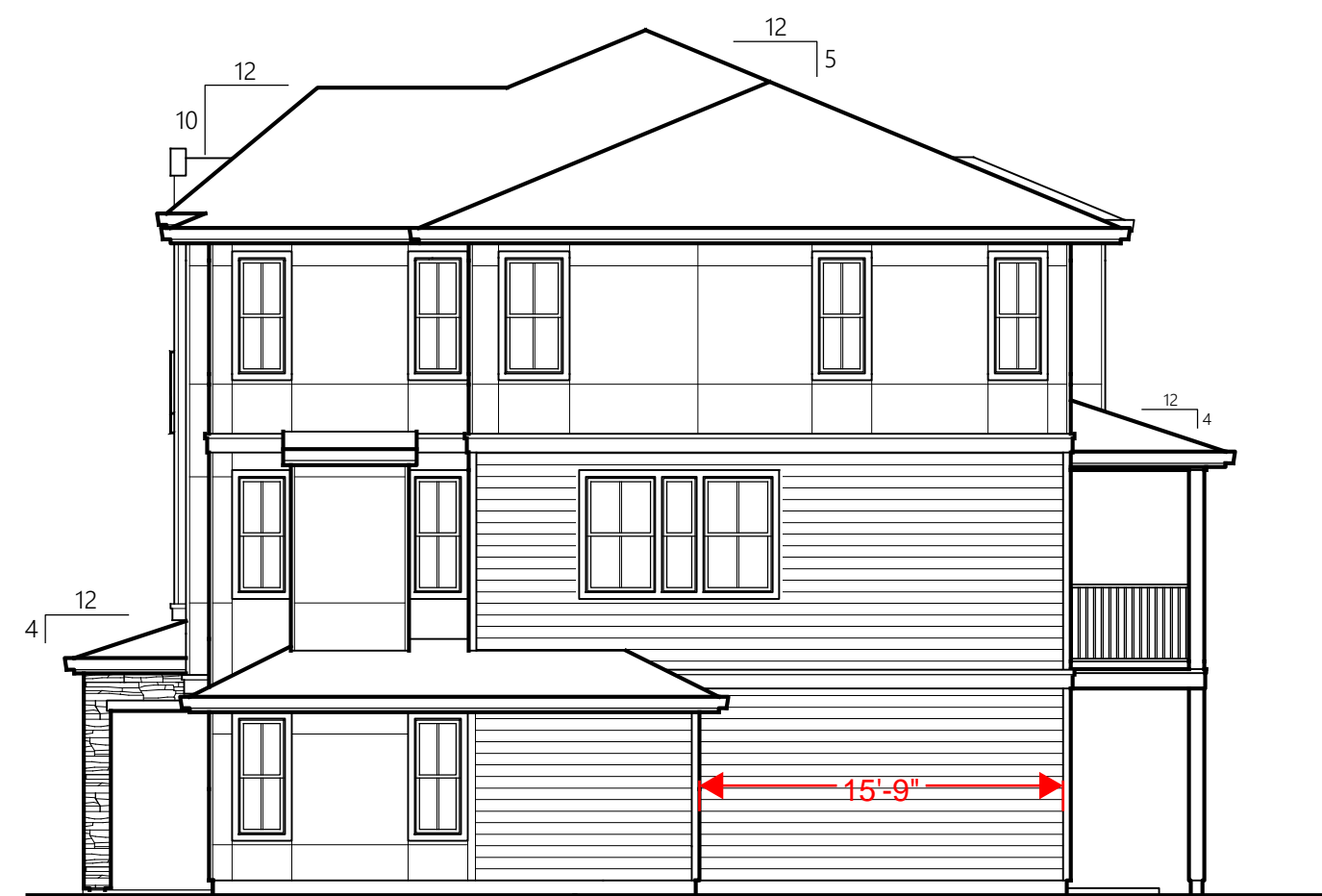

Building 1 (Lots 156-158)

1/8" = 1'-0"

**ENHANCED
SIDE ELEVATION**

CONTEMPORARY FRENCH



Building 1 (Lots 156-158)

1/8" = 1'-0"

**ENHANCED
REAR ELEVATION**

CONTEMPORARY FRENCH

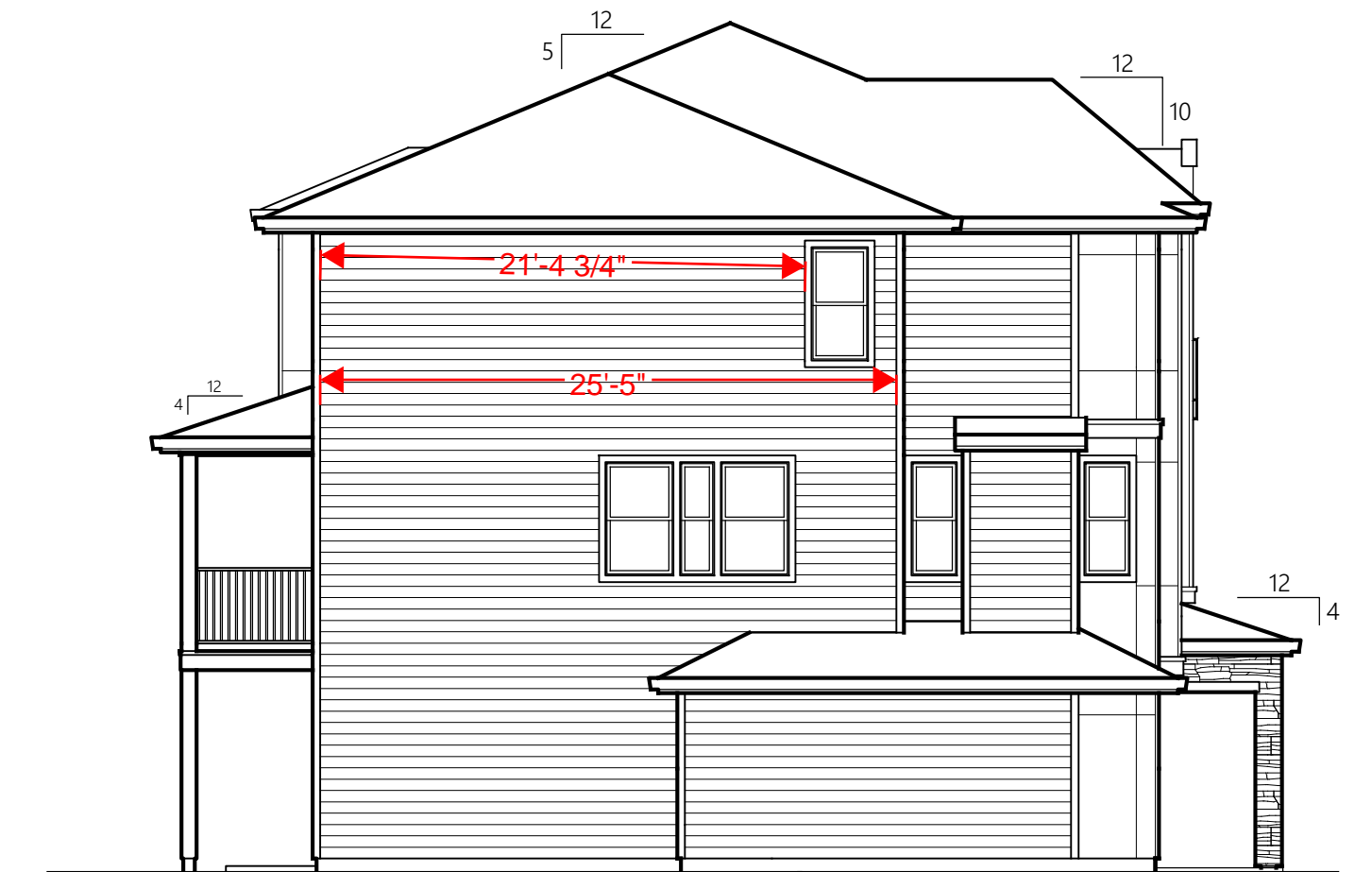

Building 1 (Lots 156-158)

1/8" = 1'-0"

SIDE ELEVATION

CONTEMPORARY FRENCH

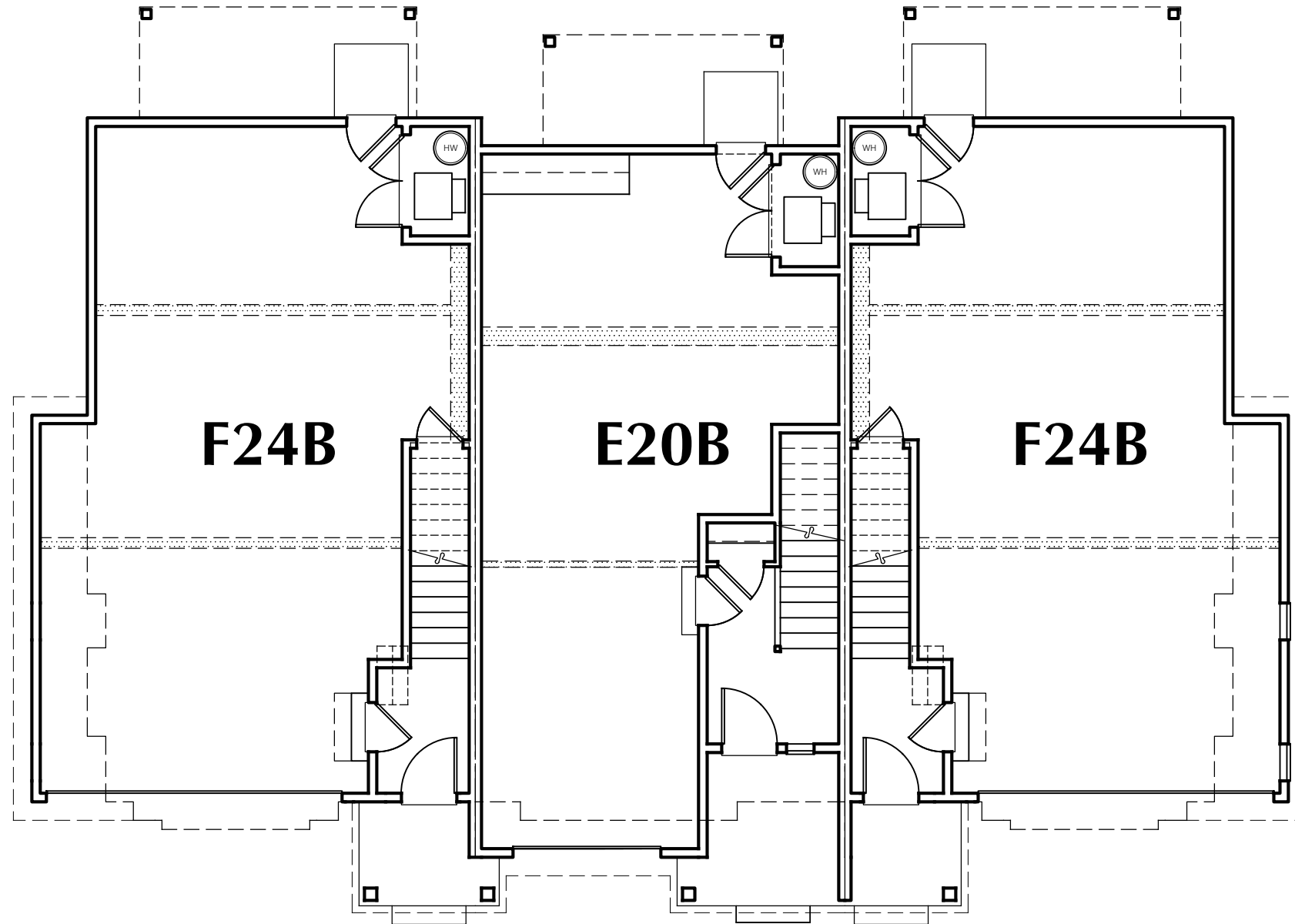

Building 1 (Lots 156-158)

LOWER LEVEL FLOOR PLAN

1/8" = 1'-0"

Building 4 (Lots 169-171)

LOWER LEVEL FLOOR PLAN

1/8" = 1'-0"



Building 1 (Lot 156)

1/8" = 1'-0"

Building 4 (Lot 169)

1/8" = 1'-0"



Building 1 (Lots 156-158)

1/8" = 1'-0"

Building 4 (Lots 169-171)

1/8" = 1'-0"

Building 7 (Lots 189-193)

1/8" = 1'-0"

5-PLEX - SIMILAR

Garage Parking

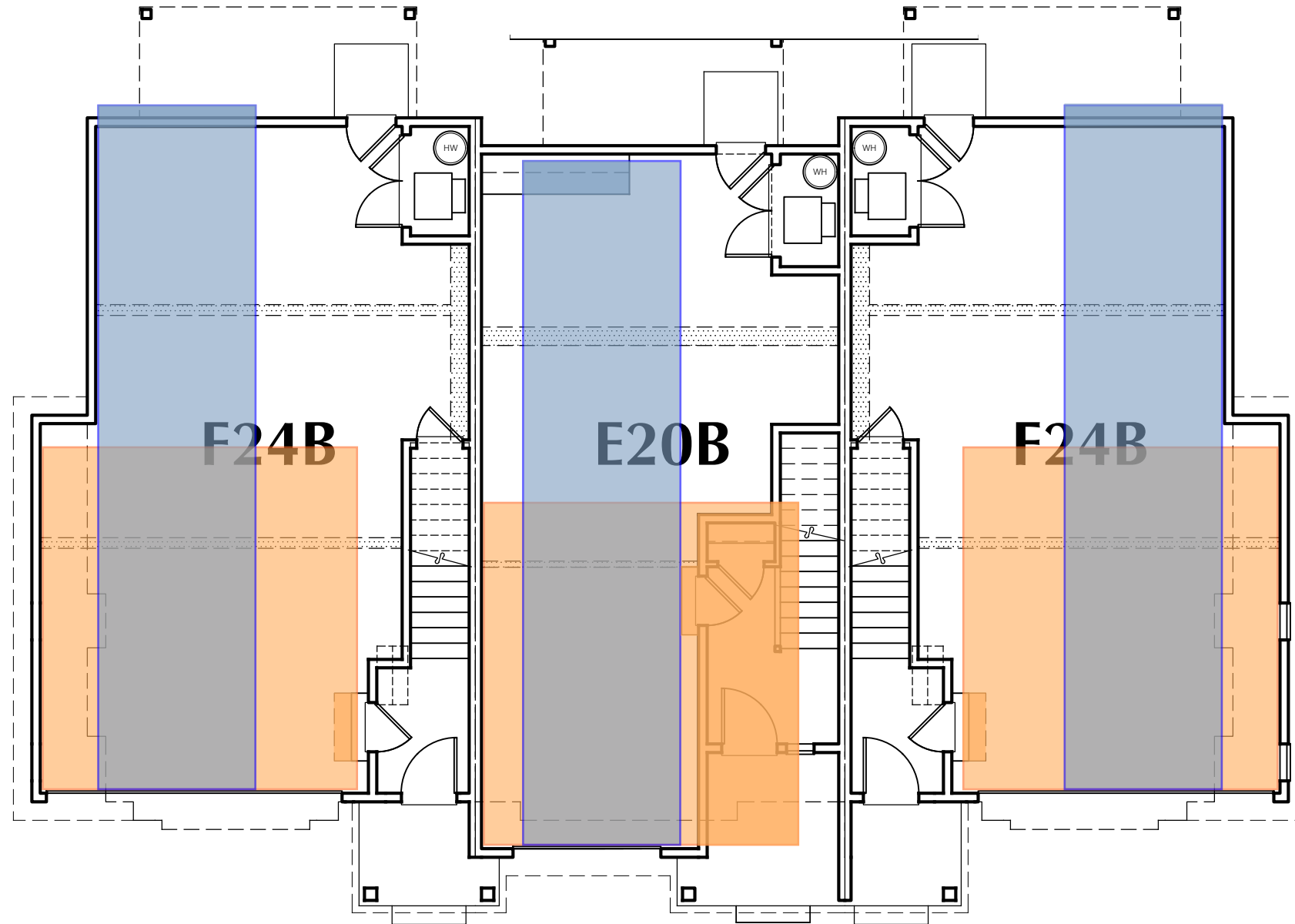

Building 1 (Lots 156-158)

LOWER LEVEL FLOOR PLAN

1/8" = 1'-0"

Building 4 (Lots 169-171)

LOWER LEVEL FLOOR PLAN

1/8" = 1'-0"

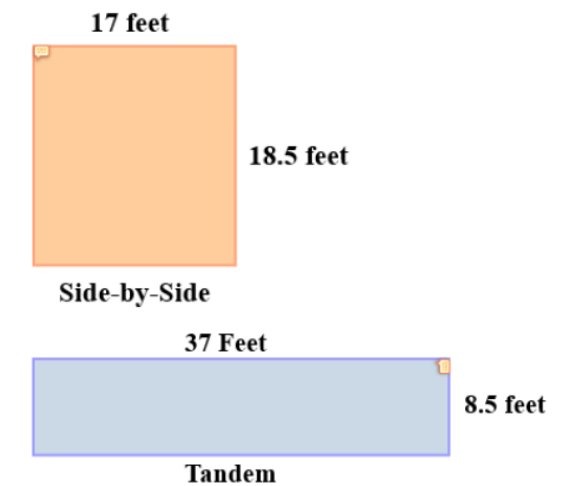

Received
Planning Division
11/03/2023



3'-0" STEP 2'-6" STEP 3'-6" STEP 2'-0" STEP
Building 2 (Lots 159-163)
3/16" = 1'-0"
ENTRY ELEVATION
MODERN FARMHOUSE



Building 2 (Lots 159-163)
1/8" = 1'-0"
SIDE ELEVATION
MODERN FARMHOUSE



2'-0" STEP 3'-6" STEP 2'-6" STEP 3'-0" STEP
Building 2 (Lots 159-163)
1/8" = 1'-0"
ENHANCED REAR ELEVATION
MODERN FARMHOUSE



Building 2 (Lots 159-163)
1/8" = 1'-0"
SIDE ELEVATION
MODERN FARMHOUSE

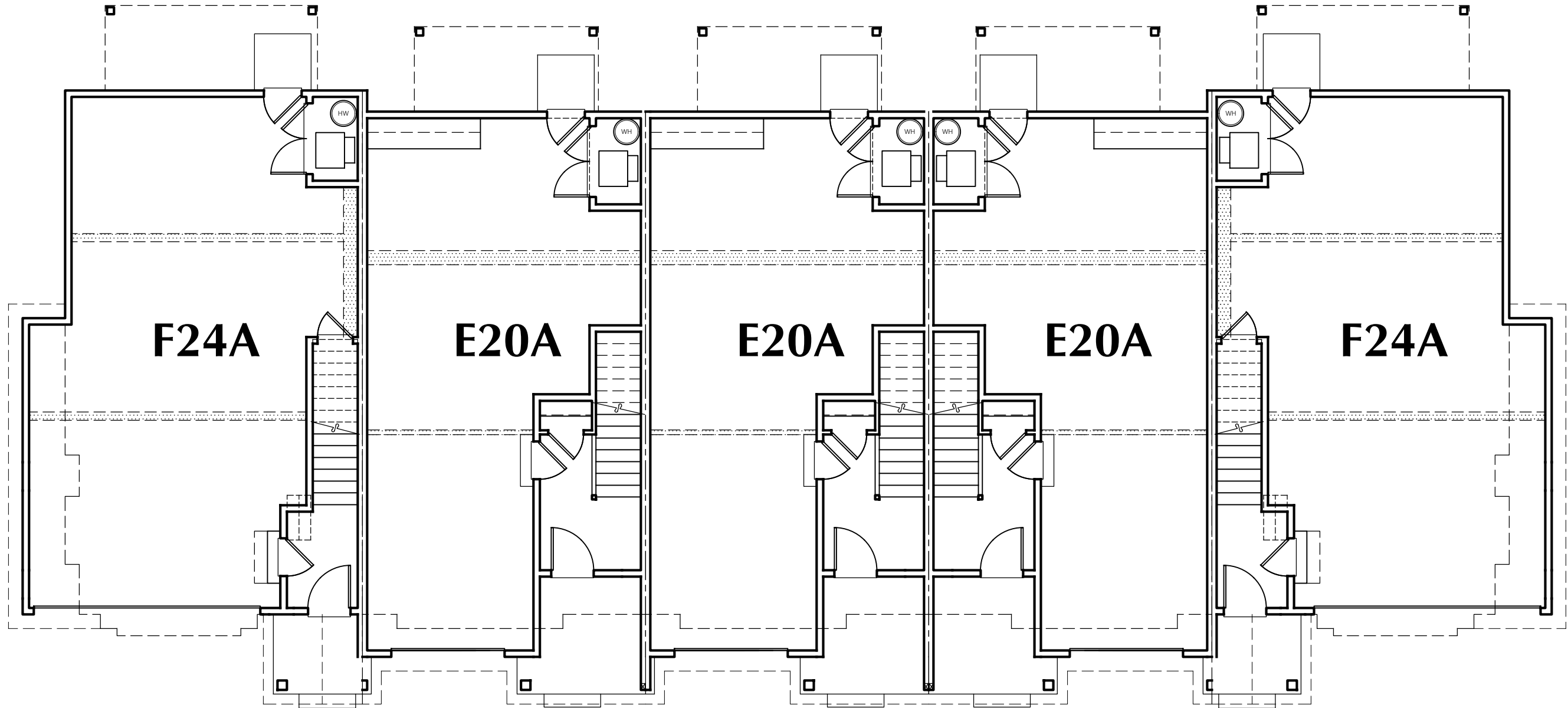

Building 2 (Lots 159-163)

LOWER LEVEL FLOOR PLAN

1/8" = 1'-0"

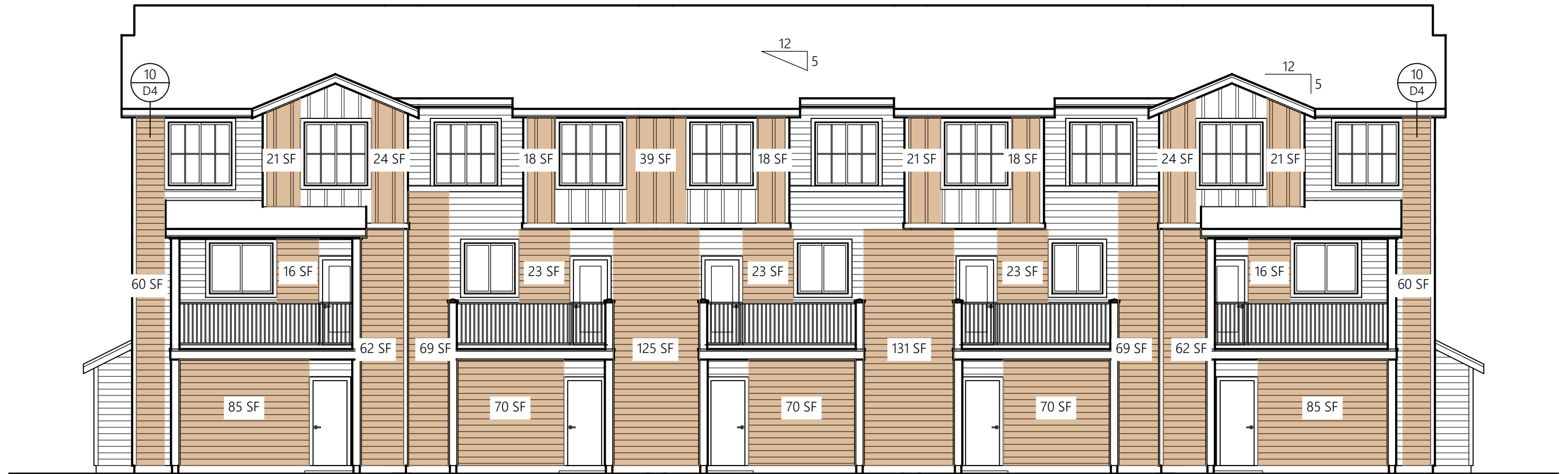

Building 2 (Lots 159-163)

1/8" = 1'-0"

Building 6 (Lots 186-188)

1/8" = 1'-0"

3-PLEX - SIMILAR

Garage Parking

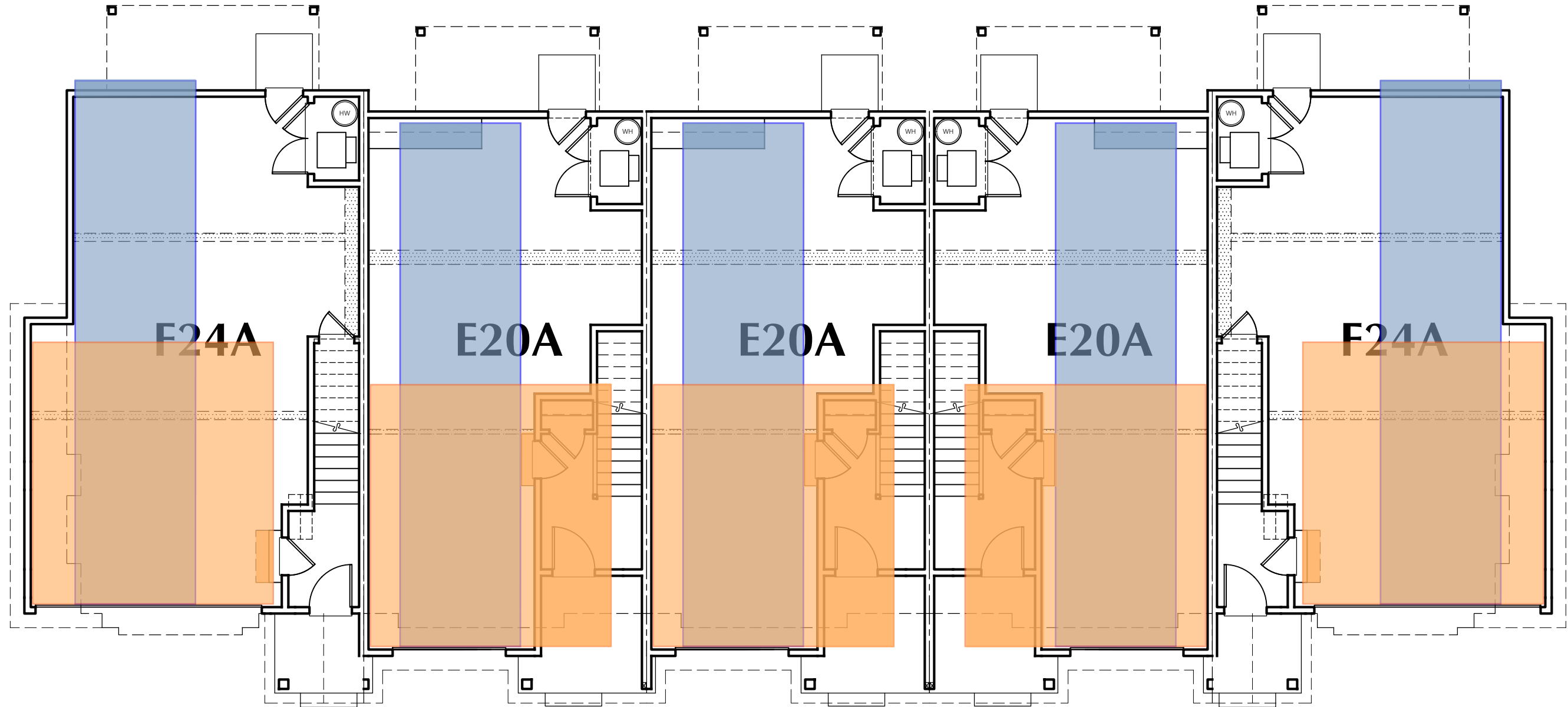

Building 2 (Lots 159-163)

LOWER LEVEL FLOOR PLAN

1/8" = 1'-0"

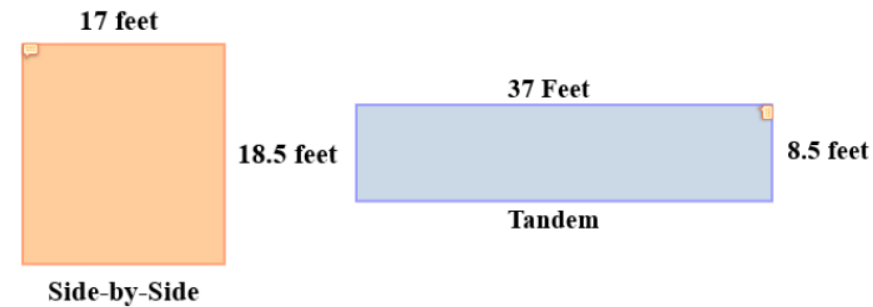

MILBRANDT
ARCHITECTS

The Vineyard at Cooper Mountain
Beaverton, Oregon

The New Home Company

Building 2
Floor Plan

Date: 9-27-23
Drawn By: RDG
Job No.: 2320

B2

Sheet No.:



2'-6" STEP 1'-6" STEP 3'-6" STEP 2'-0" STEP
Building 3 (Lots 164-168)
 3/16" = 1'-0" ENTRY ELEVATION
 CONTEMPORARY TUDOR



Building 3 (Lots 164-168)
 1/8" = 1'-0" SIDE ELEVATION
 CONTEMPORARY TUDOR



2'-0" STEP 3'-6" STEP 1'-6" STEP 2'-6" STEP
Building 3 (Lots 164-168)
 1/8" = 1'-0" ENHANCED REAR ELEVATION
 CONTEMPORARY TUDOR



Building 3 (Lots 164-168)
 1/8" = 1'-0" ENHANCED SIDE ELEVATION
 CONTEMPORARY TUDOR

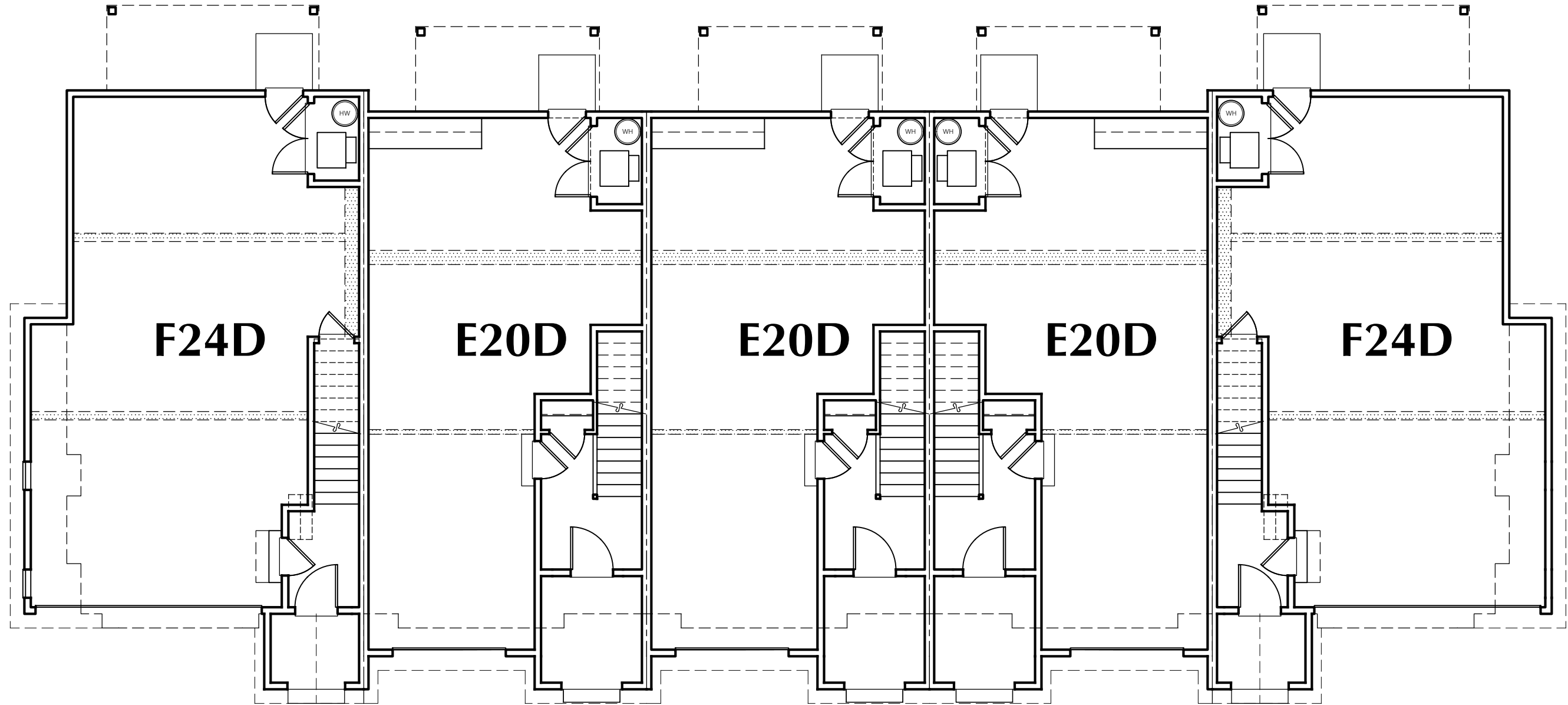

Building 3 (Lots 164-168)

LOWER LEVEL FLOOR PLAN

1/8" = 1'-0"

Building 8 (Lots 194-198)

LOWER LEVEL FLOOR PLAN

1/8" = 1'-0"



Building 3 (Lot 168)

1/8" = 1'-0"

Building 5 (Lot 174)

1/8" = 1'-0"

Building 8 (Lot 198)

1/8" = 1'-0"



Building 3 (Lots 164-168)

1/8" = 1'-0"

Building 5 (Lots 172-174)

1/8" = 1'-0"

3-PLEX - SIMILAR

Building 8 (Lots 194-198)

1/8" = 1'-0"

Garage Parking

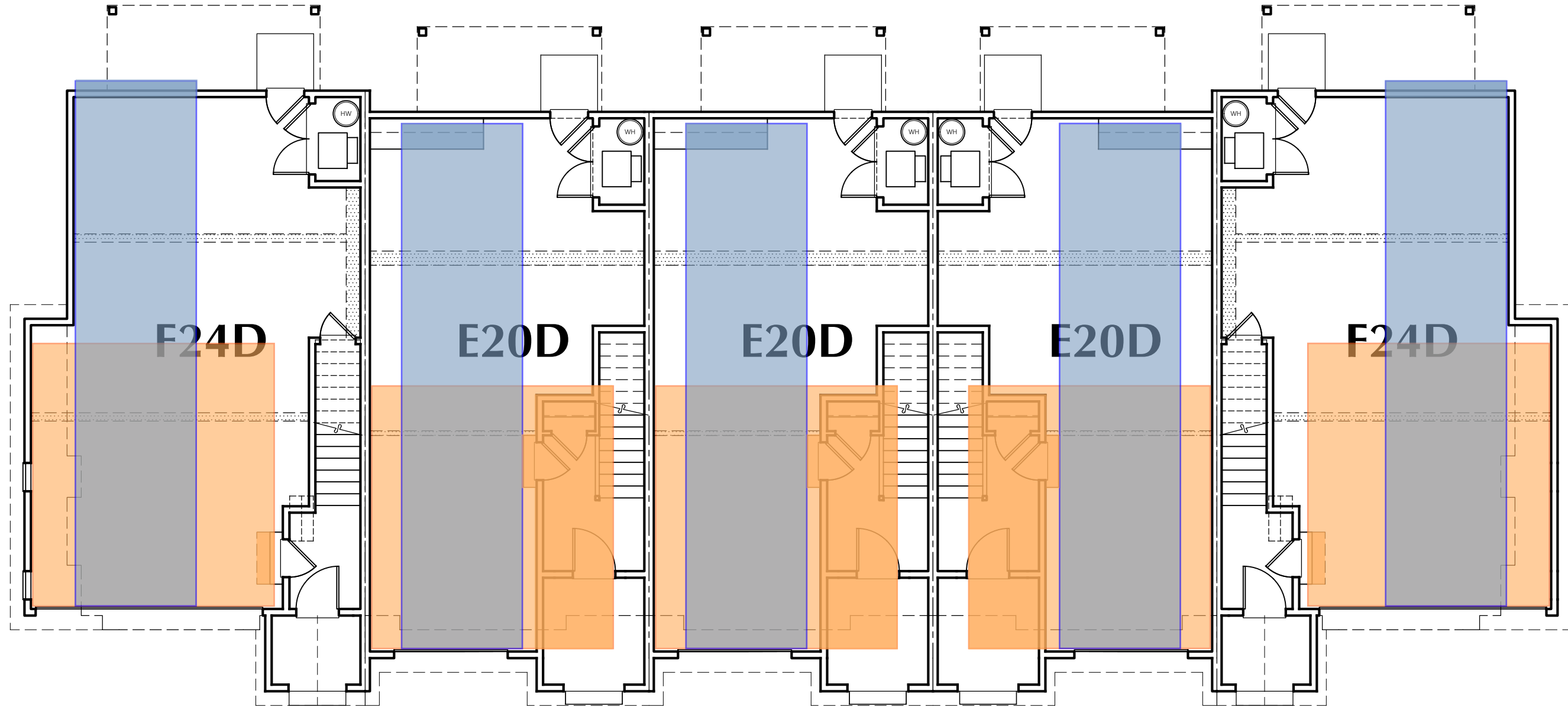

Building 3 (Lots 164-168)

LOWER LEVEL FLOOR PLAN

1/8" = 1'-0"

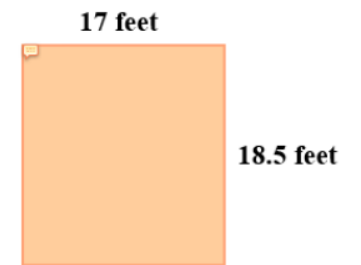

Side-by-Side

Building 8 (Lots 194-198)

LOWER LEVEL FLOOR PLAN

1/8" = 1'-0"

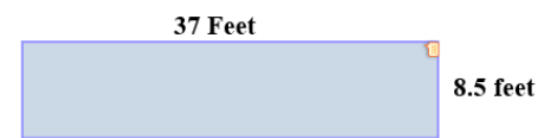

Tandem



Building 4 (Lots 169-171)

3/16" = 1'-0"

ENTRY ELEVATION
CONTEMPORARY FRENCH



Building 4 (Lots 169-171)

1/8" = 1'-0"

ENHANCED
SIDE ELEVATION
CONTEMPORARY FRENCH



Building 4 (Lots 169-171)

1/8" = 1'-0"

ENHANCED
REAR ELEVATION
CONTEMPORARY FRENCH



Building 4 (Lots 169-171)

1/8" = 1'-0"

SIDE ELEVATION
CONTEMPORARY FRENCH

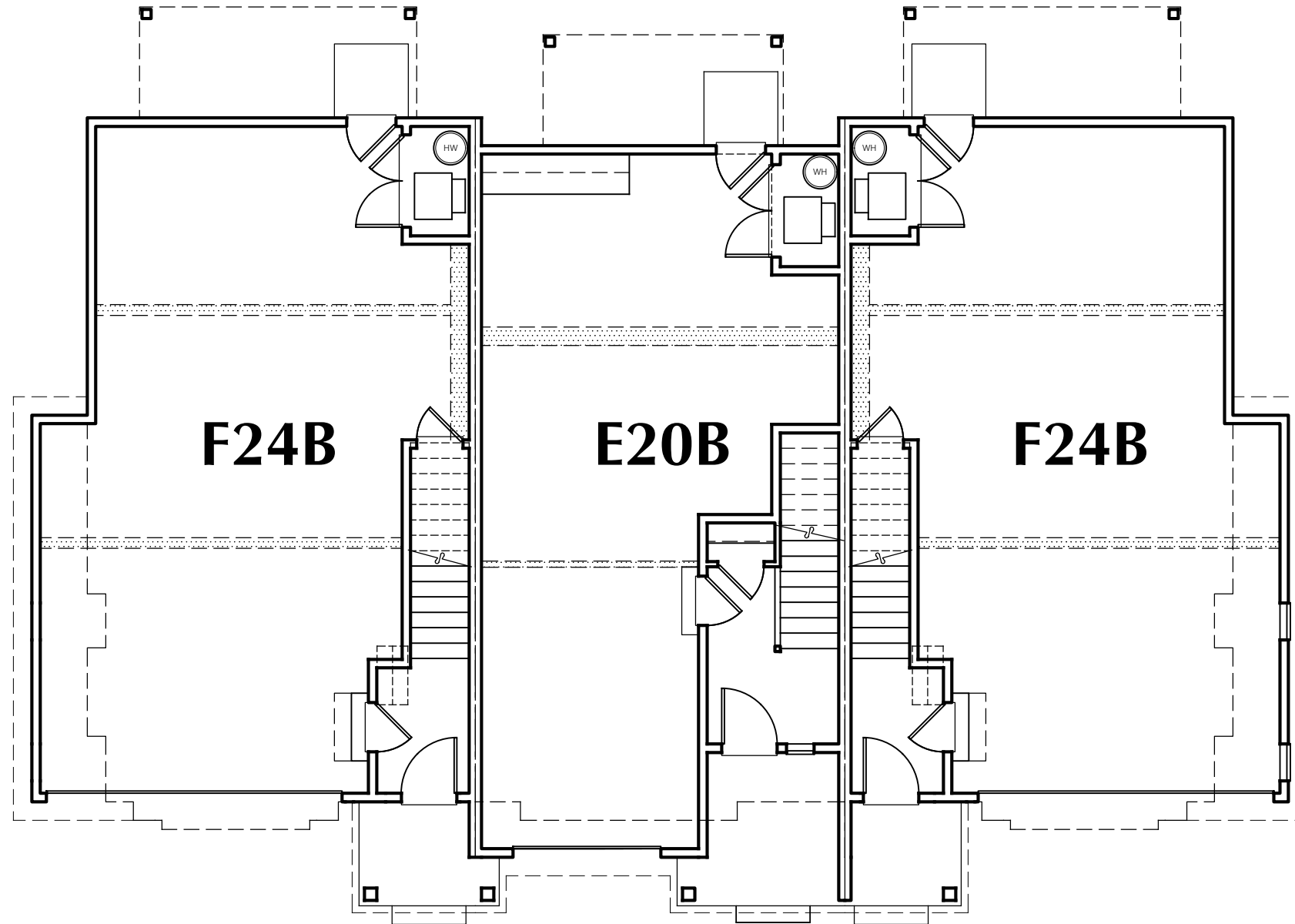

Building 1 (Lots 156-158)

LOWER LEVEL FLOOR PLAN

1/8" = 1'-0"

Building 4 (Lots 169-171)

LOWER LEVEL FLOOR PLAN

1/8" = 1'-0"



Building 1 (Lot 156)

1/8" = 1'-0"

Building 4 (Lot 169)

1/8" = 1'-0"



Building 1 (Lots 156-158)

1/8" = 1'-0"

Building 4 (Lots 169-171)

1/8" = 1'-0"

Building 7 (Lots 189-193)

1/8" = 1'-0"

5-PLEX - SIMILAR

Garage Parking

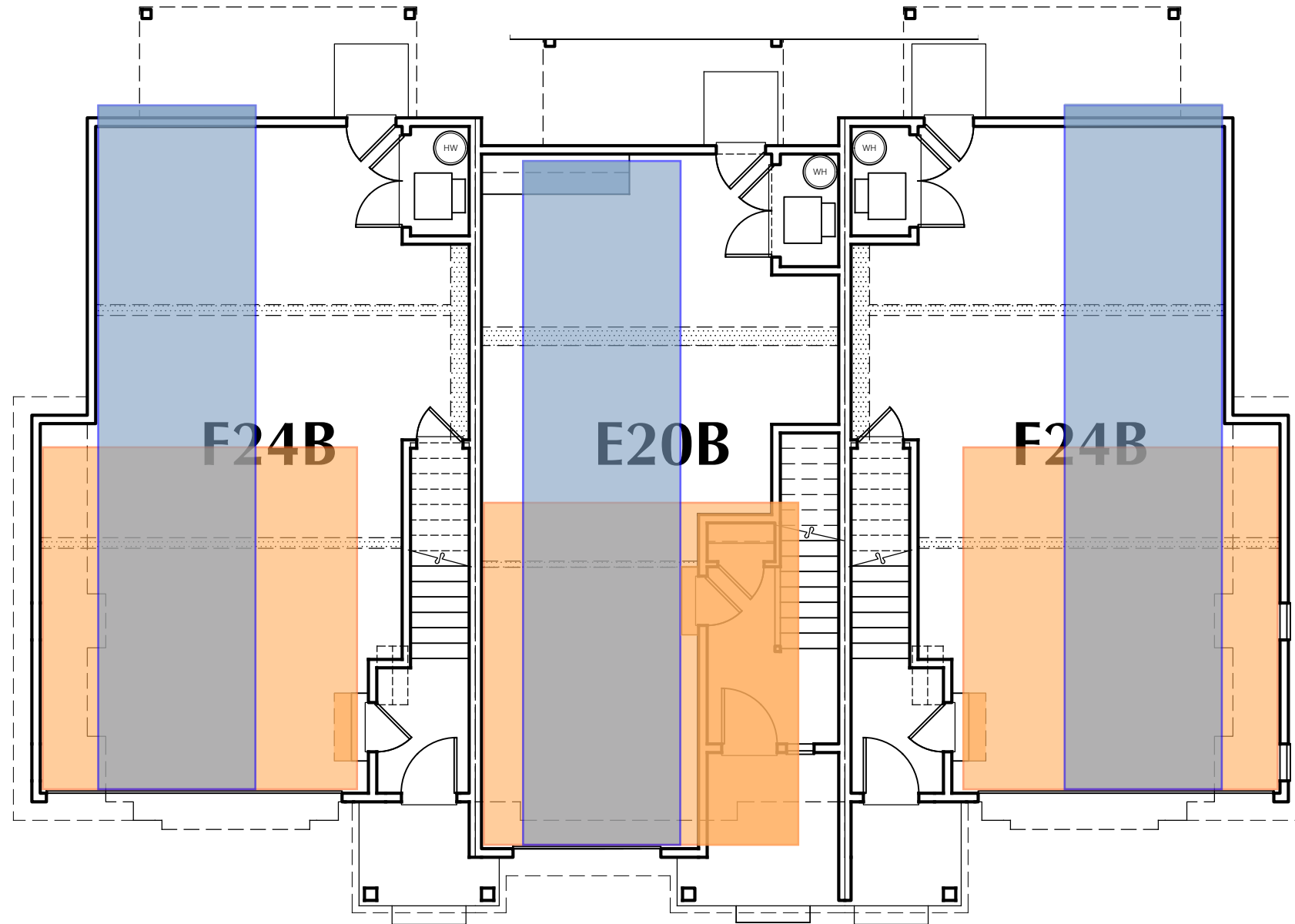

Building 1 (Lots 156-158)

LOWER LEVEL FLOOR PLAN

1/8" = 1'-0"

Building 4 (Lots 169-171)

LOWER LEVEL FLOOR PLAN

1/8" = 1'-0"

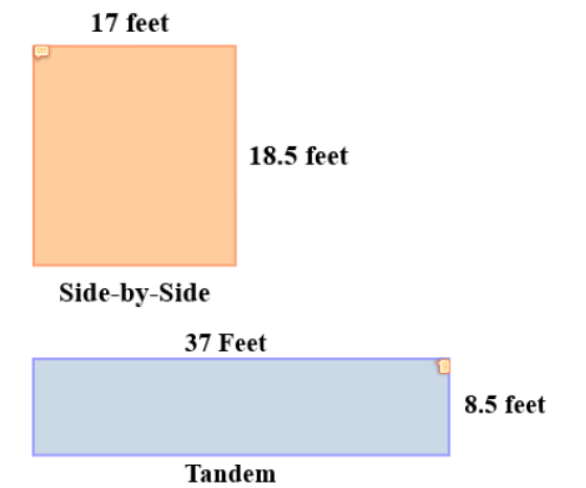



Building 5 (Lots 172-174)
 3/16" = 1'-0"

ENTRY ELEVATION
 CONTEMPORARY TUDOR



Building 5 (Lots 172-174)
 1/8" = 1'-0" SIDE ELEVATION
 CONTEMPORARY TUDOR



Building 5 (Lots 172-174)
 1/8" = 1'-0"

ENHANCED
 REAR ELEVATION
 CONTEMPORARY TUDOR



Building 5 (Lots 172-174)
 1/8" = 1'-0"

ENHANCED
 SIDE ELEVATION
 CONTEMPORARY TUDOR

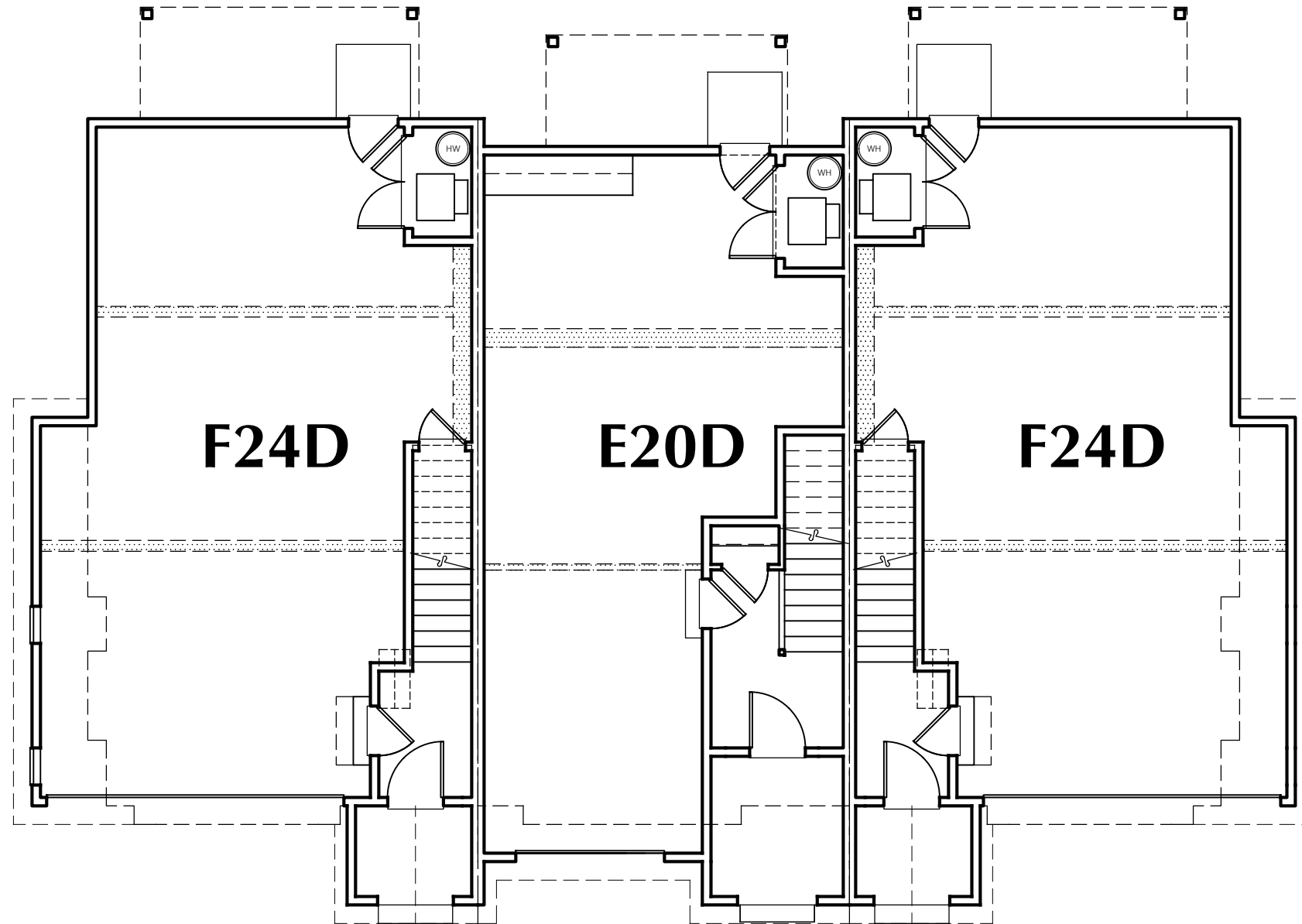

Building 5 (Lots 172-174)

LOWER LEVEL FLOOR PLAN

1/8" = 1'-0"



Building 3 (Lot 168)

1/8" = 1'-0"

Building 5 (Lot 174)

1/8" = 1'-0"

Building 8 (Lot 198)

1/8" = 1'-0"

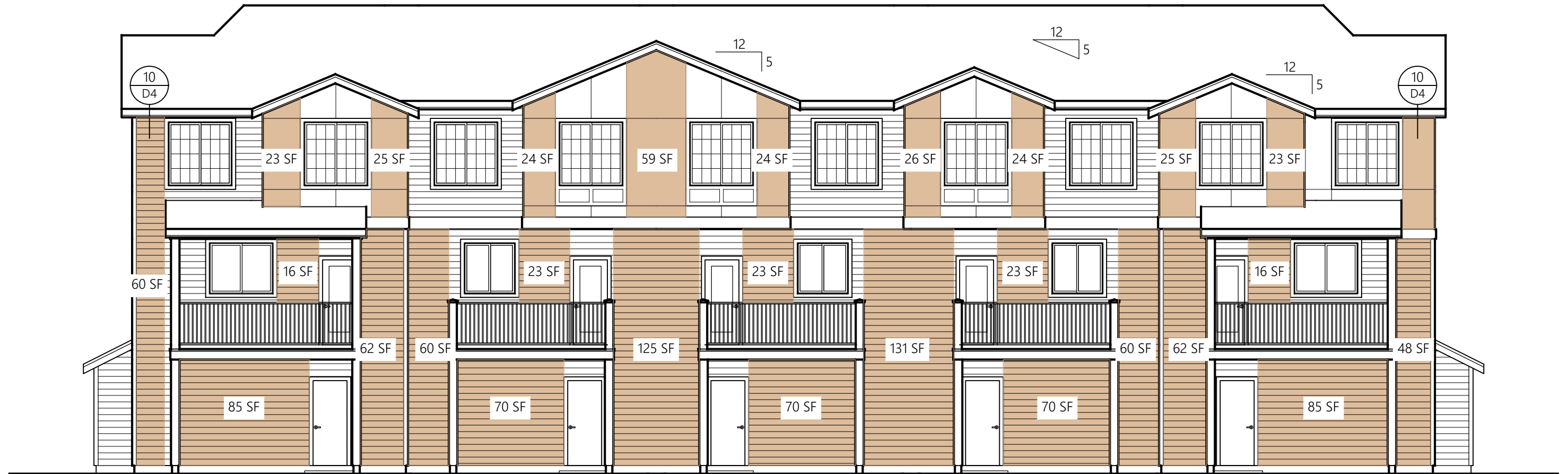

Building 3 (Lots 164-168)

1/8" = 1'-0"

Building 5 (Lots 172-174)

1/8" = 1'-0"

3-PLEX - SIMILAR

Building 8 (Lots 194-198)

1/8" = 1'-0"

Garage Parking

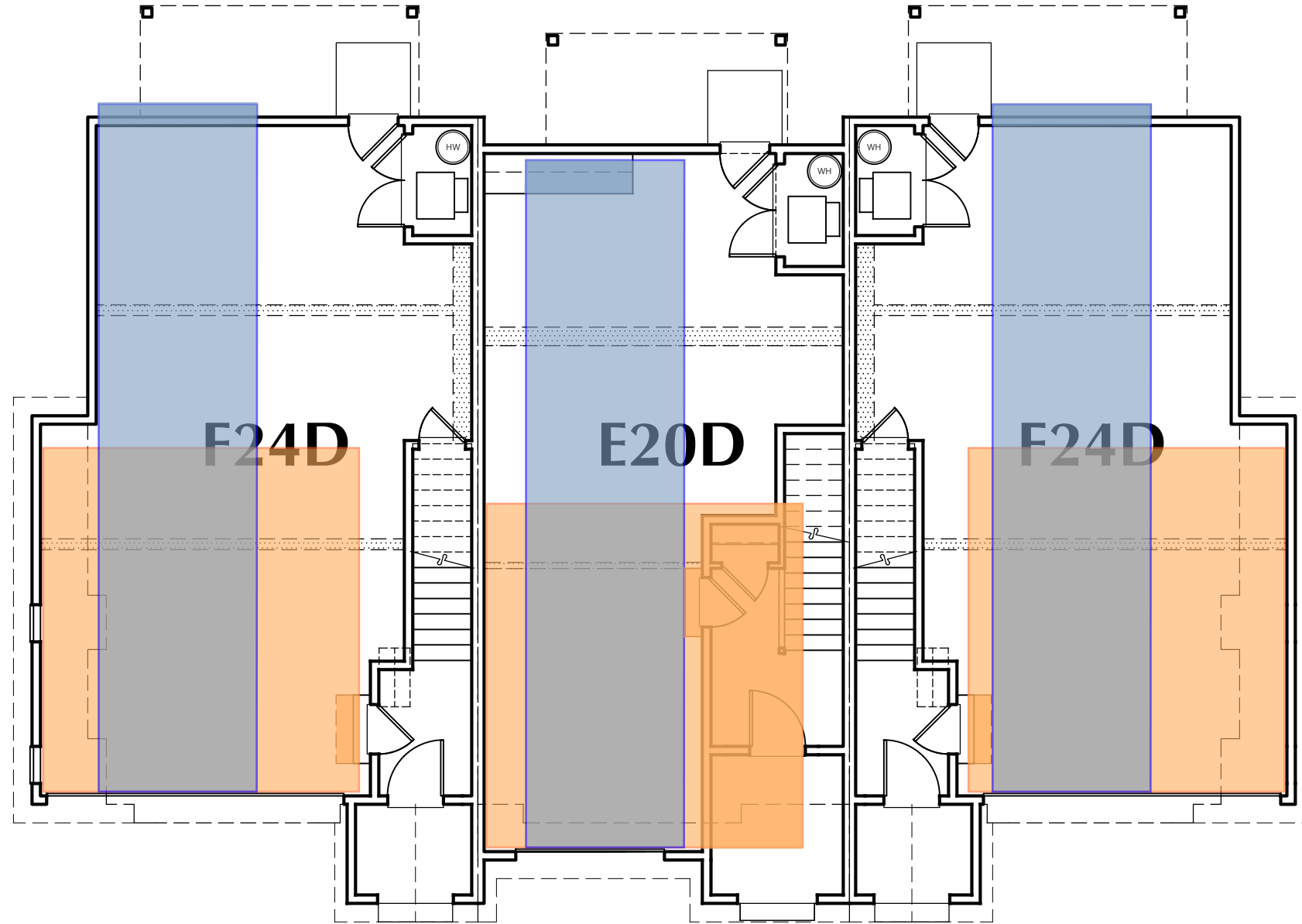

Building 5 (Lots 172-174)

LOWER LEVEL FLOOR PLAN

1/8" = 1'-0"

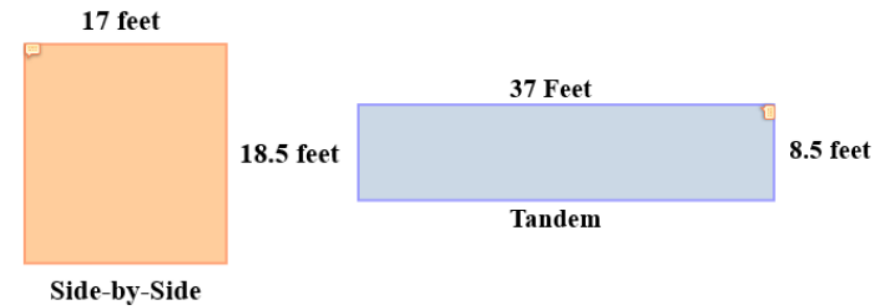



Building 6 (Lots 186-188) ENTRY ELEVATION
 3/16" = 1'-0" MODERN FARMHOUSE



Building 6 (Lots 186-188) ENHANCED SIDE ELEVATION
 1/8" = 1'-0" MODERN FARMHOUSE



Building 6 (Lots 186-188) ENHANCED REAR ELEVATION
 1/8" = 1'-0" MODERN FARMHOUSE



Building 6 (Lots 186-188) SIDE ELEVATION
 1/8" = 1'-0" MODERN FARMHOUSE

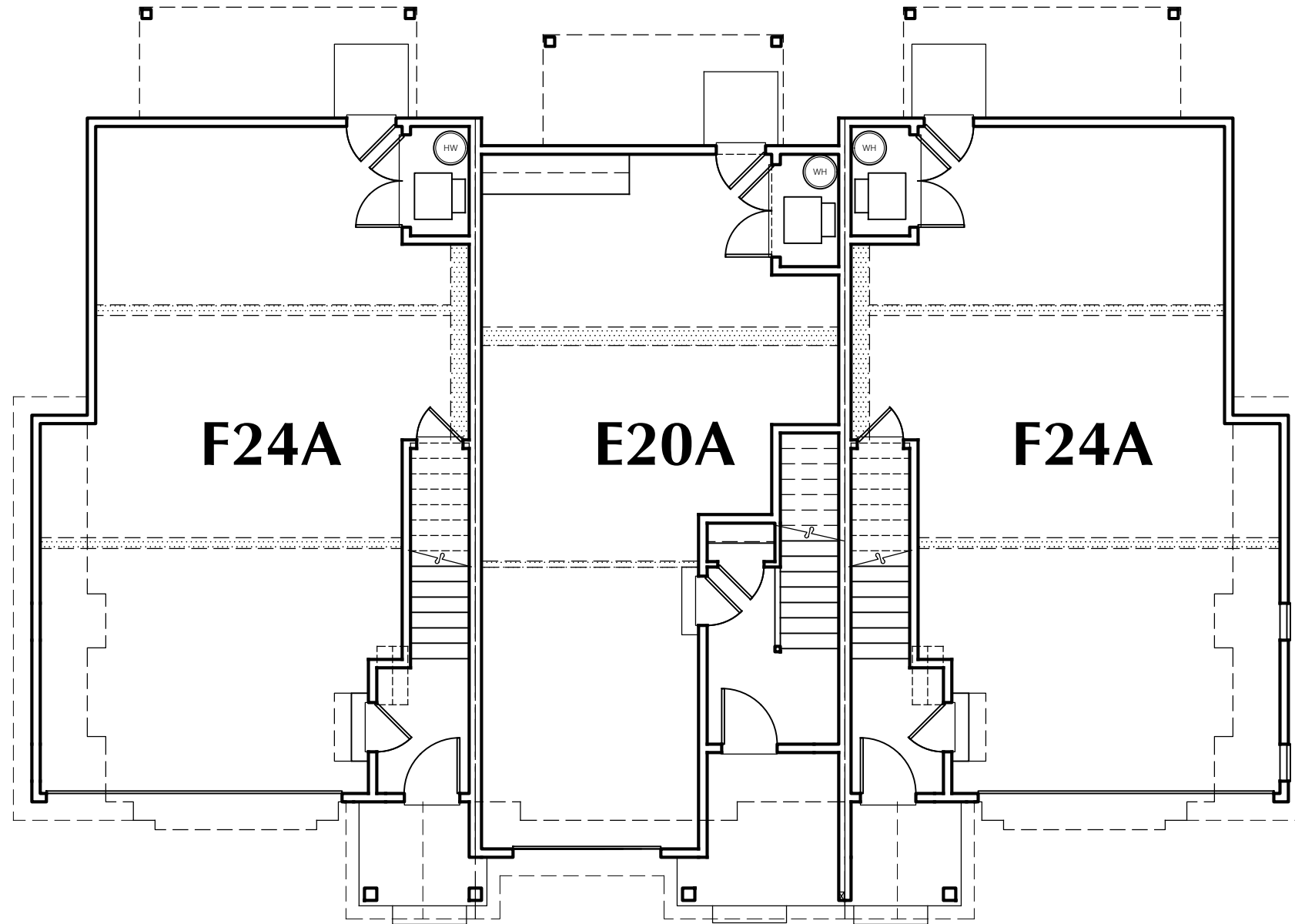

Building 6 (Lots 186-188)

LOWER LEVEL FLOOR PLAN

1/8" = 1'-0"



Building 6 (Lot 186)

1/8" = 1'-0"

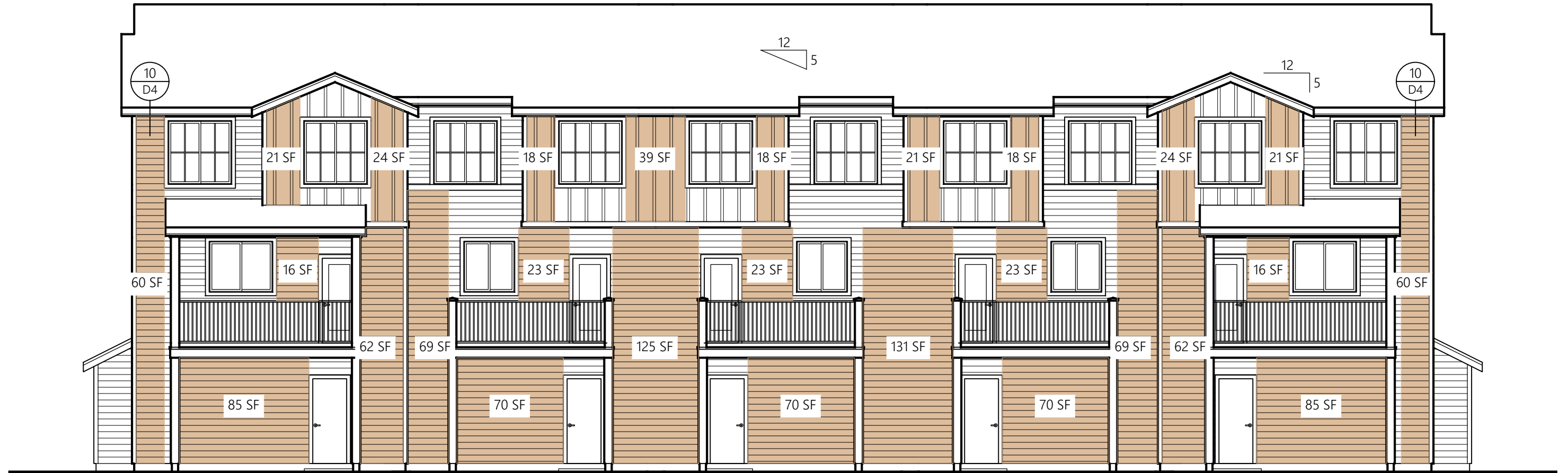

Building 2 (Lots 159-163)

1/8" = 1'-0"

Building 6 (Lots 186-188)

1/8" = 1'-0"

3-PLEX - SIMILAR

Garage Parking

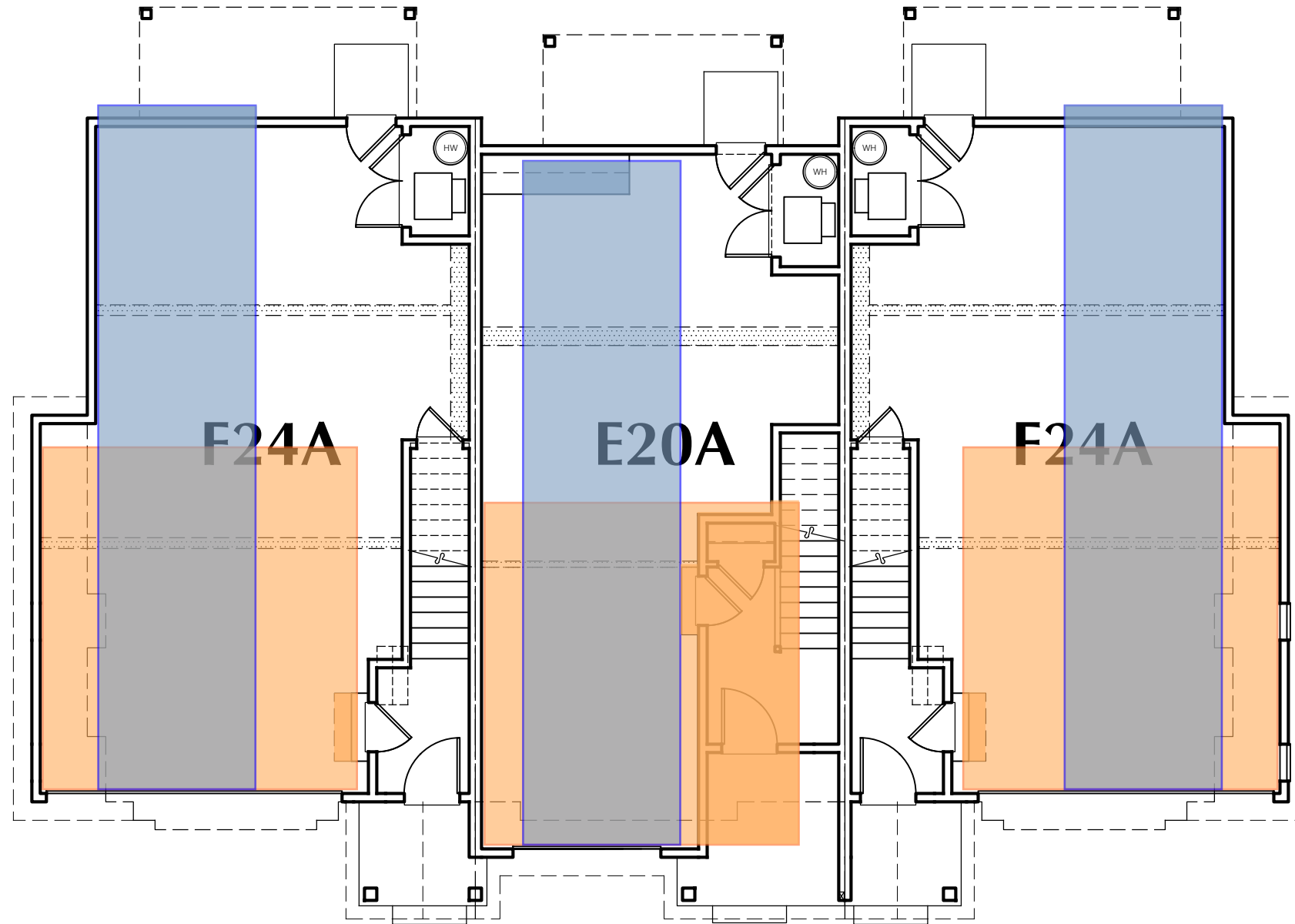

Building 6 (Lots 186-188)

LOWER LEVEL FLOOR PLAN

1/8" = 1'-0"

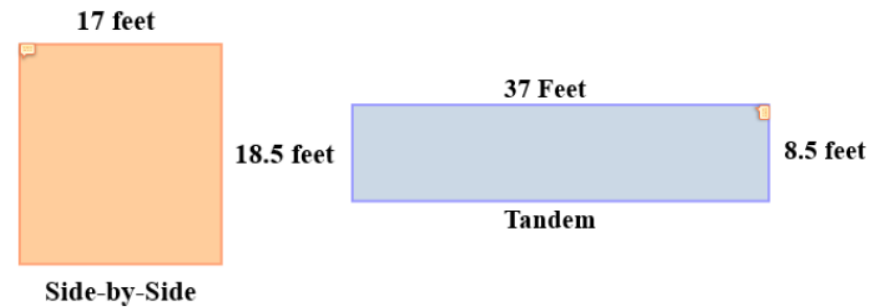

Received
Planning Division
11/03/2023

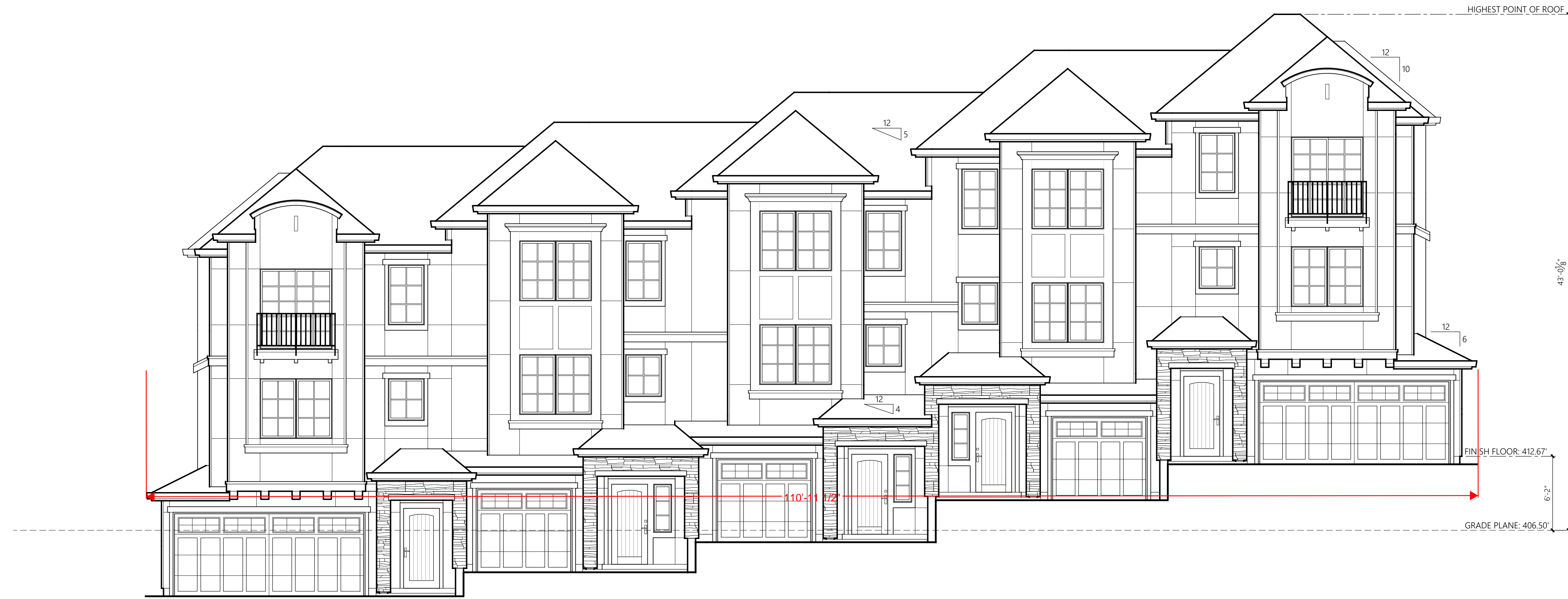

Building 7 (Lots 189-193) ENTRY ELEVATION
3/16" = 1'-0" CONTEMPORARY FRENCH



Building 7 (Lots 189-193) SIDE ELEVATION
1/8" = 1'-0" CONTEMPORARY FRENCH

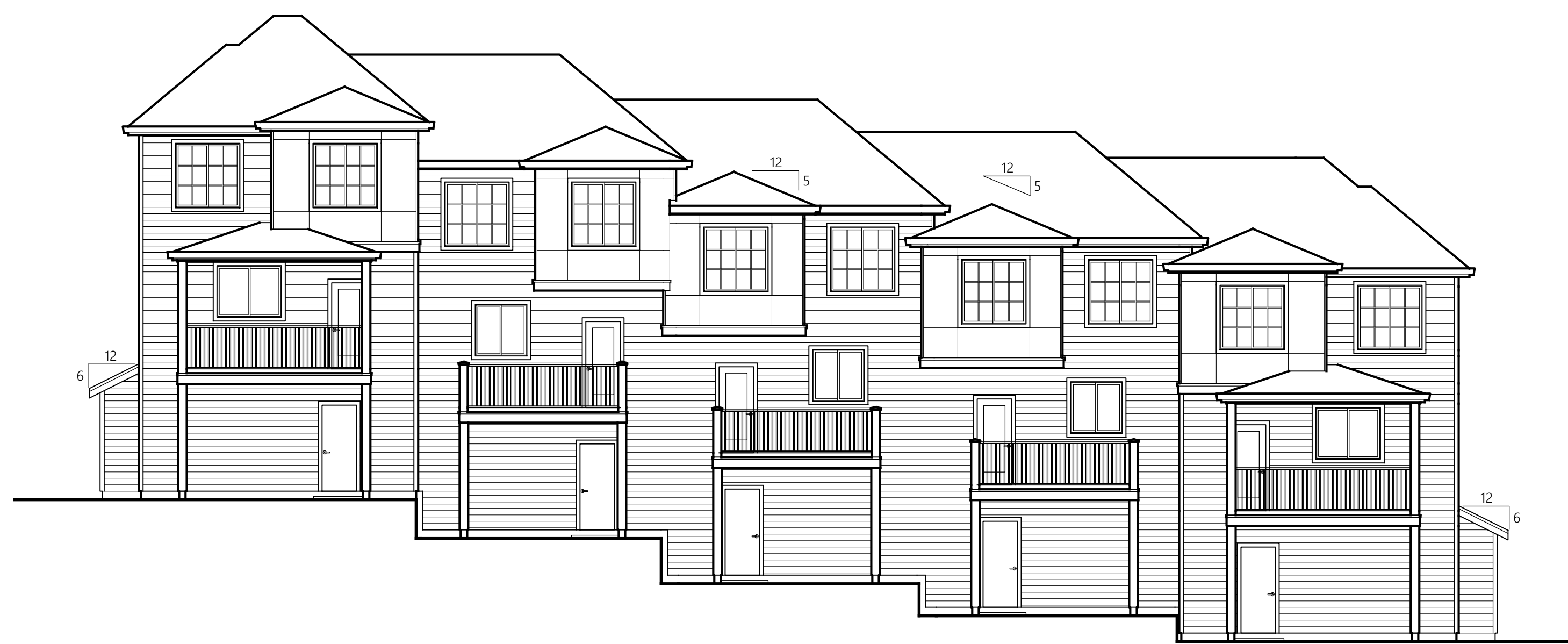

Building 7 (Lots 189-193) ENHANCED REAR ELEVATION
1/8" = 1'-0" CONTEMPORARY FRENCH



Building 7 (Lots 189-193) SIDE ELEVATION
1/8" = 1'-0" CONTEMPORARY FRENCH

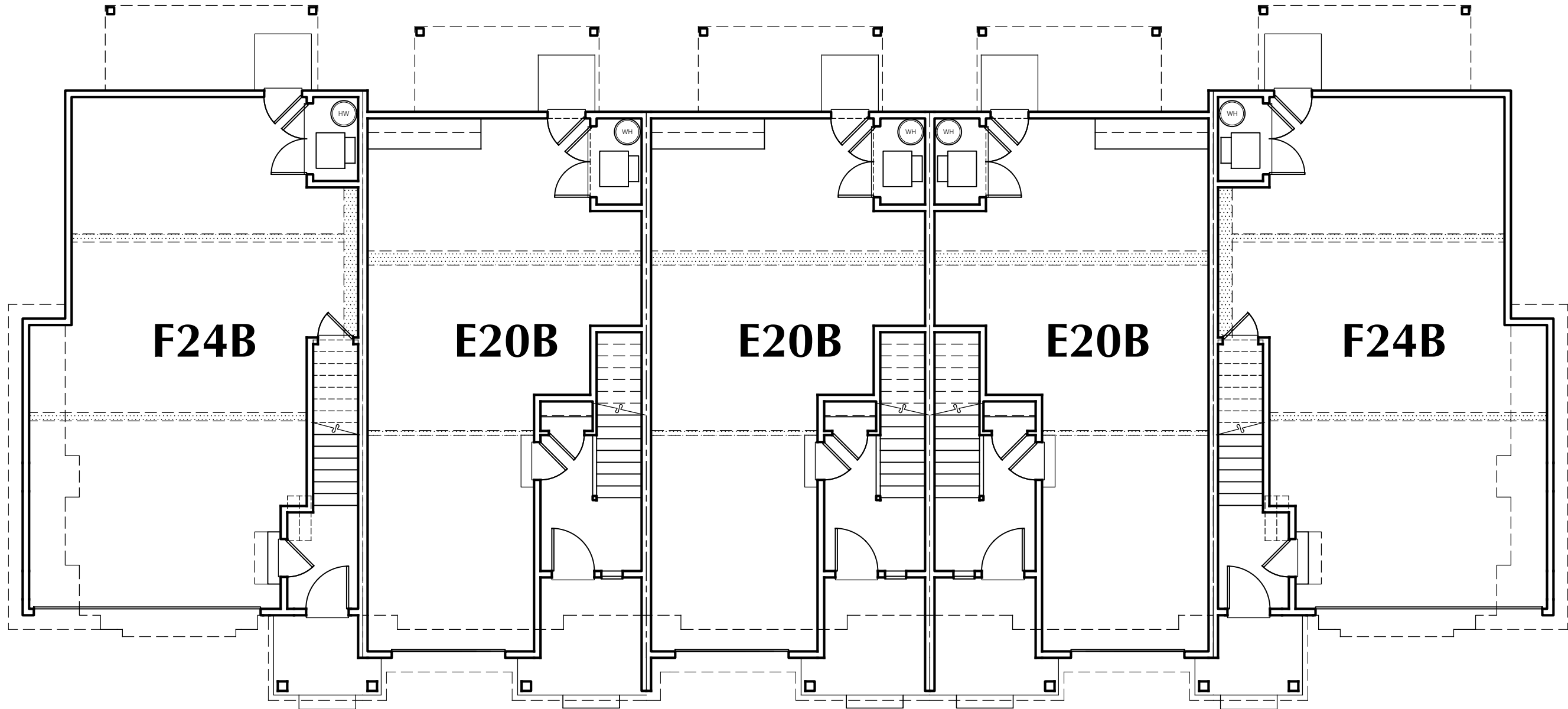

Building 7 (Lots 189-193)

1/8" = 1'-0"

LOWER LEVEL FLOOR PLAN



Building 1 (Lots 156-158)

1/8" = 1'-0"

Building 4 (Lots 169-171)

1/8" = 1'-0"

Building 7 (Lots 189-193)

1/8" = 1'-0"

5-PLEX - SIMILAR

Garage Parking

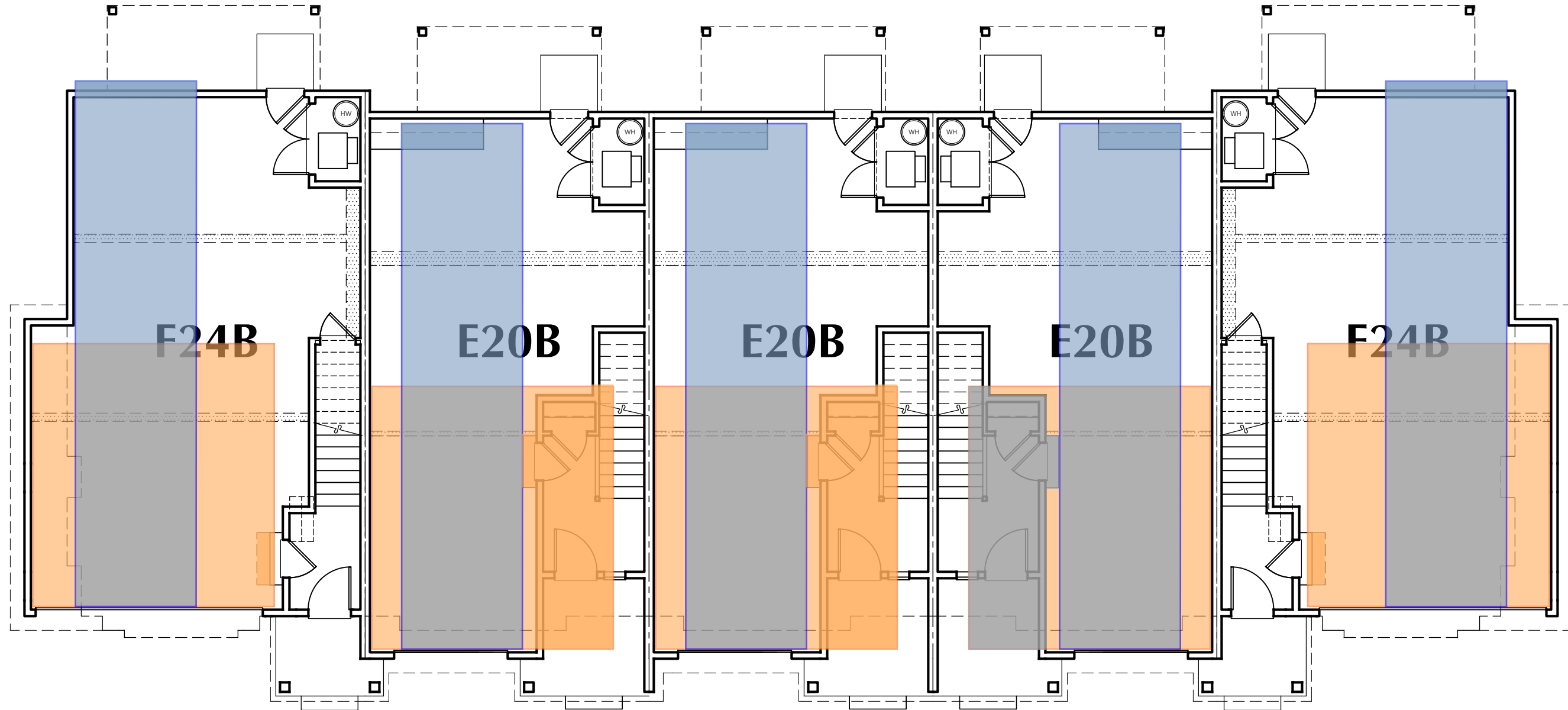

Building 7 (Lots 189-193)

1/8" = 1'-0"

LOWER LEVEL FLOOR PLAN

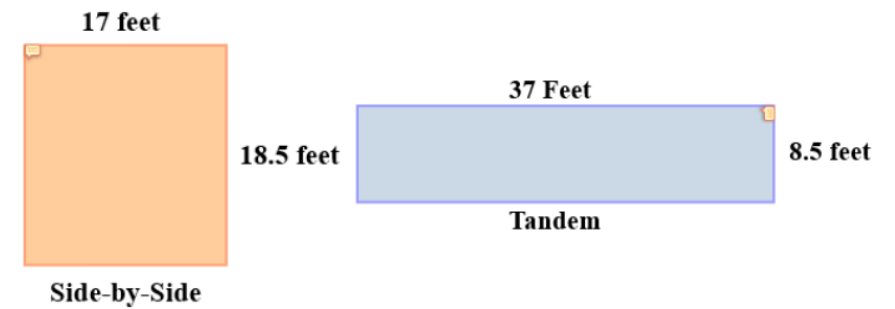

MILBRANDT
ARCHITECTS

The Vineyard at Cooper Mountain The New Home Company
Beaverton, Oregon

Building 7
Floor Plan

Date: 9-27-23
Drawn By: RDG
Job No.: 2320

B6

Sheet No.:



3'-0" STEP
2'-0" STEP
2'-6" STEP
3'-6" STEP
Building 8 (Lots 194-198)
3/16" = 1'-0"
ENTRY ELEVATION
CONTEMPORARY TUDOR



Building 8 (Lots 194-198)
1/8" = 1'-0"
SIDE ELEVATION
CONTEMPORARY TUDOR



3'-6" STEP
2'-6" STEP
2'-0" STEP
3'-0" STEP
Building 8 (Lots 194-198)
1/8" = 1'-0"
ENHANCED
REAR ELEVATION
CONTEMPORARY TUDOR



Building 8 (Lots 194-198)
1/8" = 1'-0"
ENHANCED
SIDE ELEVATION
CONTEMPORARY TUDOR

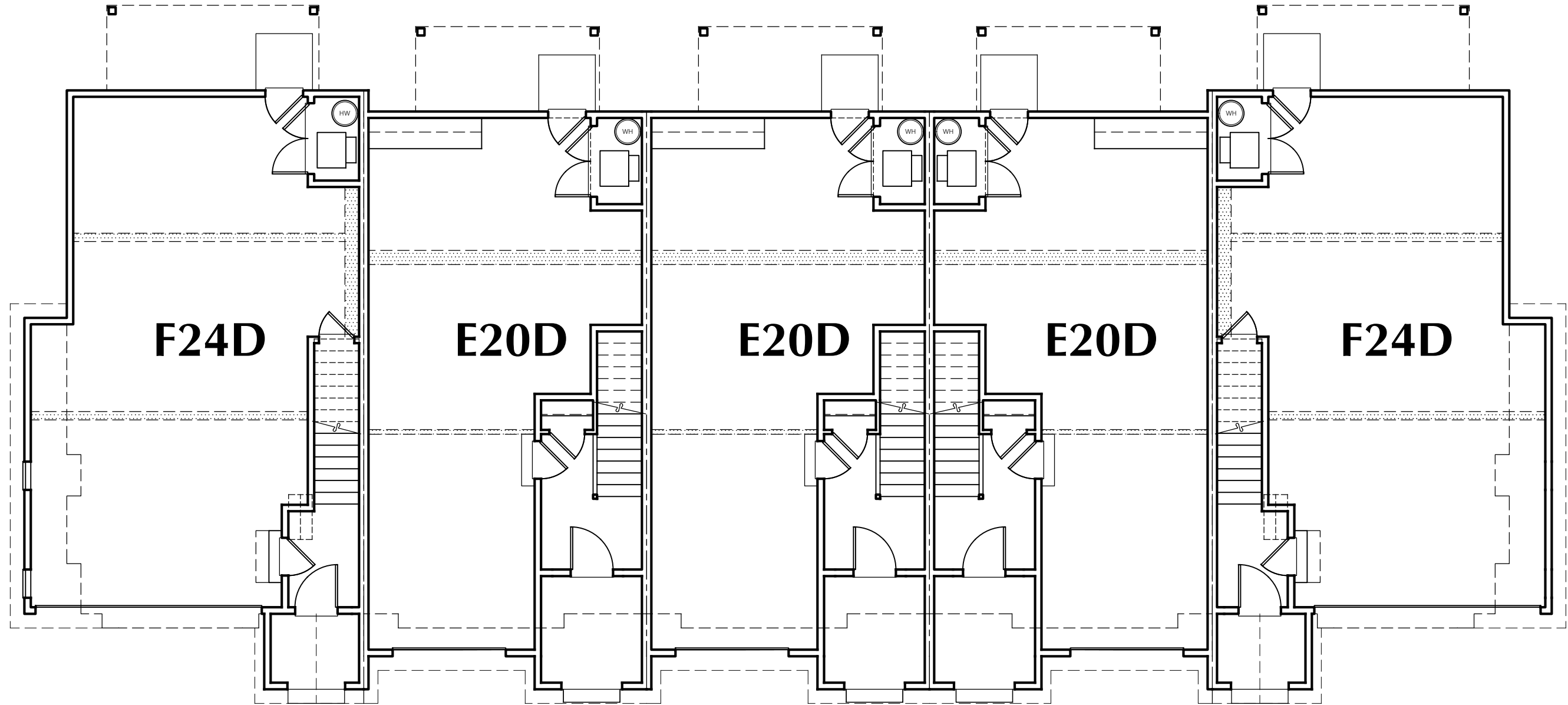

Building 3 (Lots 164-168)

LOWER LEVEL FLOOR PLAN

1/8" = 1'-0"

Building 8 (Lots 194-198)

LOWER LEVEL FLOOR PLAN

1/8" = 1'-0"



Building 3 (Lot 168)

1/8" = 1'-0"

Building 5 (Lot 174)

1/8" = 1'-0"

Building 8 (Lot 198)

1/8" = 1'-0"



Building 3 (Lots 164-168)

1/8" = 1'-0"

Building 5 (Lots 172-174)

1/8" = 1'-0"

3-PLEX - SIMILAR

Building 8 (Lots 194-198)

1/8" = 1'-0"

Garage Parking

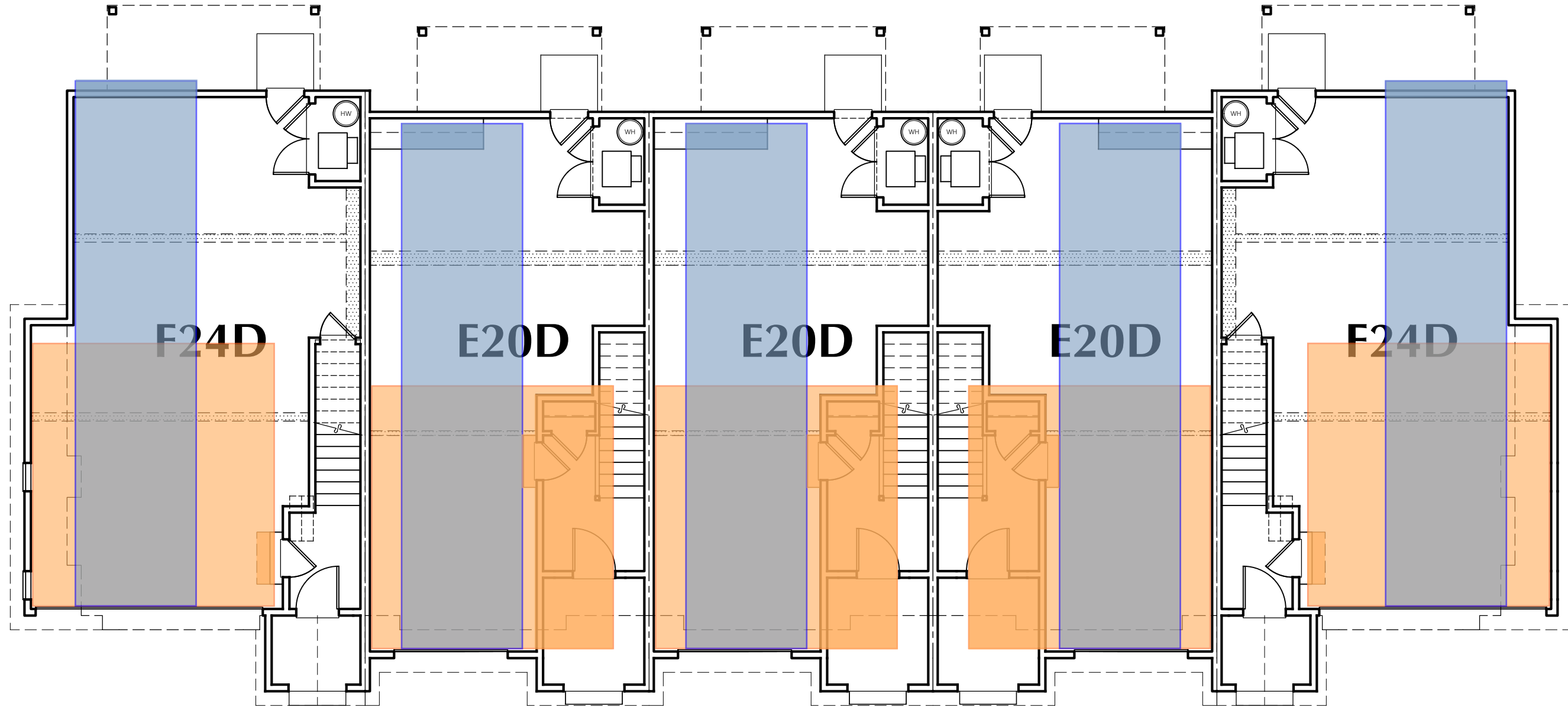

Building 3 (Lots 164-168)

LOWER LEVEL FLOOR PLAN

1/8" = 1'-0"

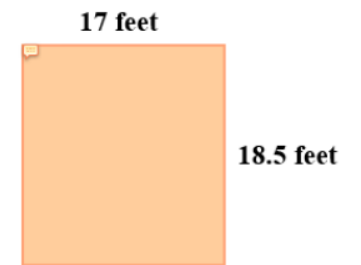

Side-by-Side

Building 8 (Lots 194-198)

LOWER LEVEL FLOOR PLAN

1/8" = 1'-0"

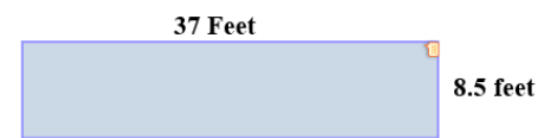

Tandem